

1/2"- 2" BSP UPVC Fact Acting Non-Return Electric Actuated Ball Valve MO & Visual Indicator

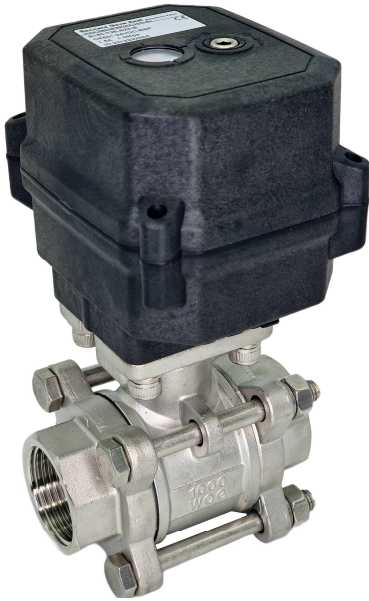

Motorized Water Valve is ideal for draining water tank, water heater, water treatments, brewing and water meters.

Design Features

- Beautiful appearance, compact structure, high precision, large output torque, service life is not less than 50,000 times
- The actuator and valve can be assembled from multiple angles, which is convenient for users to allocate space
- Ball valve adopts floating soft seal structure, no drip leakage, suitable for heavy dirt and long-term no action occasions
- Protection grade **IP68**, can be used in relatively humid environment.

Technical Data

Product size	1/2", 3/4", 1", 1 1/4", 1 1/2", 2" BSP	Valve Body Material	304 Stainless Steel
Maximum working pressure	1.0 MPa (10 bar)	Actuator Material	Polyphenylene Oxide
Open/close time	≤2 sec / 90°	Sealing Material	EPDM, FKM & PTFE
Working voltage	DC12V, DC24V	Manual Override	Yes
Wiring control methods	CR201, CR501, CR303	Visual Indicator	Yes
Working current	≤2A (DC12V), ≤1A (DC24V)	Feedback	Yes (only with CR501)
Locked Rotor Current	5A (DC12V), 3.5A (DC24V)	IP Rating	IP68



Max. torque force	15 N.m	Environment temperature	-15°C~50°C
Lifetime	50,000 times at least	Liquid temperature	2°C~90°C
Cable Length	0.5m	Actuator rotation	90°
Cable Specification	UL 2464 22awg	Circulation medium	Fluid, air

Wiring Diagrams

■ CR201 Wiring Diagram (2 wires control)

·RD connect with positive, the BK connect with negative, the valve closed, the actuator automatically power off after in place , the valve remains fully closed position
 ·BK connect with positive, the RD connect with negative, the valve open, the actuator automatically power off after in place, the valve remains fully open position

- Suitable Working Voltage: DC5V,DC12V,DC24V
- Exceeding the working voltage is forbidden

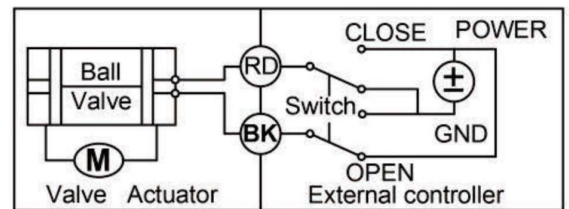

■ CR303 Wiring Diagram (3 wires control)

·RD & GR connect with positive, the BK connect with negative
 ·SW CLOSED, the valve OPEN, the actuator automatically power off after in place
 ·SW OPEN, the valve CLOSED, the actuator automatically power off after in place

- Suitable Working Voltage: AC/DC9-24V,AC110-230V
- Exceeding the working voltage is forbidden

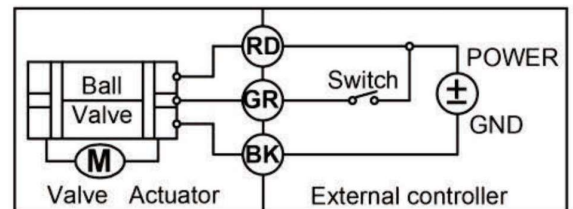

■ CR501 Wiring Diagram (5 wires control with feedback signal)

·RD connect with positive, the BK connect with negative, the valve closed, the actuator automatically power off after in place
 ·BK connect with positive, the RD connect with negative, the valve open, the actuator automatically power off after in place
 ·GR & WT connect with the valve's fully open signal wiring
 ·YW & WT connect with the valve's fully closed signal wiring
 Suitable Working Voltage:DC5V,DC12V,DC24V
 Exceeding the working voltage is forbidden

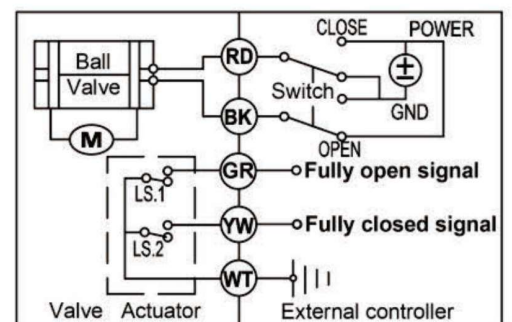

Construction Diagram

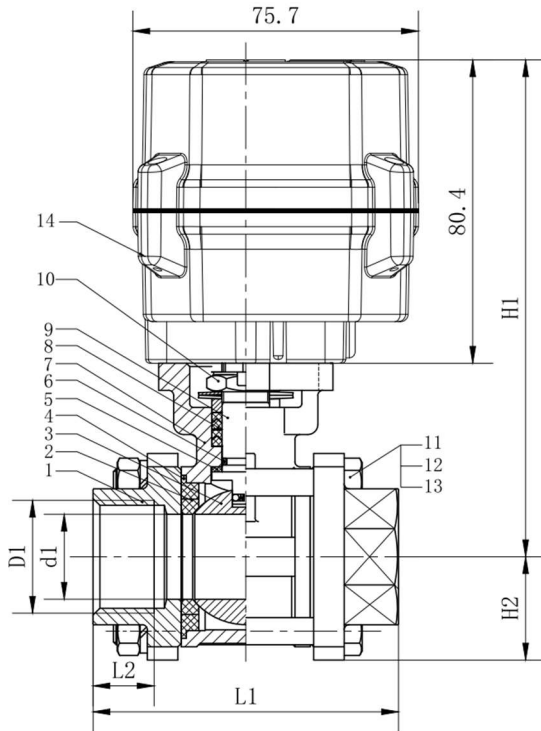

Components

No.	Name	Material	Specification	Quantity
1	Bonnet	Stainless Steel	304	2
2	Seat	PTFE		2
3	Ball	Stainless Steel	304	2
4	Gasket	PTFE		1
5	Stem Gasket	PTFE		1
6	O-Ring	FKM		2
7	Body	Stainless Steel	304	1
8	Packing	PTFE		2
9	Stem	Stainless Steel	304	1
10	Packing Gland	Stainless Steel	304	1
11	Bolt	Stainless Steel	304	4
12	Spring Washer	Stainless Steel	304	4
13	Nut	Stainless Steel	304	4
14	Actuator	PPO		1

DESCRIPTION	D1	d1±0.5	L1±1	L2±1	H1±1	H2
15-S23-B	1/2"	15	70	14	123.4	24
20-S23-B	3/4"	20	80	16	127.4	28
25-S23-B	1"	25	87	17	136.4	30

