

Specification

Model	3A1	3A2	4A1	4A2
Bore No.	6A			
Port size	1/8			
No. of port	3		5	
Medium	Air			
Operating pressure range (MPa)	0.15~0.8	0~0.8	0.15~0.8	0~0.8
Proof pressure	1 MPa			
Effective orifice	12 mm ²			
Pilot pressure range	(0.45×P*+0.1)~0.8 MPa			
Ambient temperature	-5~+60°C (No freezing)			
Weight	61 g	74 g	71 g	84 g

* P: Operating pressure.

Order example of valve

MVAA – 180 – 4A2 – NC – G

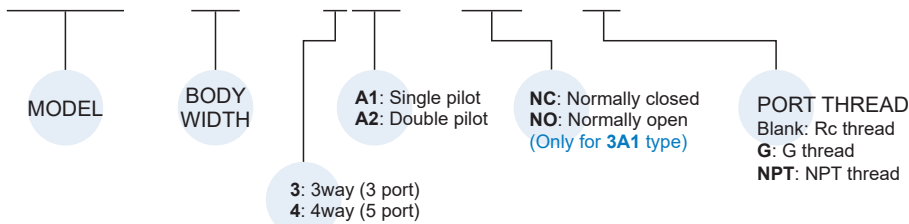

Order example of manifold

MVSC1 – 180 – 3B3 – G

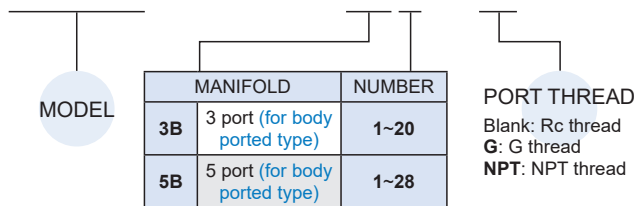

* Use the same manifold with MVSC1.

* Starting from 11 stations, manifolds are made to order.

* Use the same blocking plate with MVSC1.

Order example of blocking plate

MVSC1 – 180 – 5P

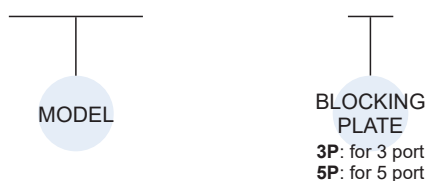

Flow features

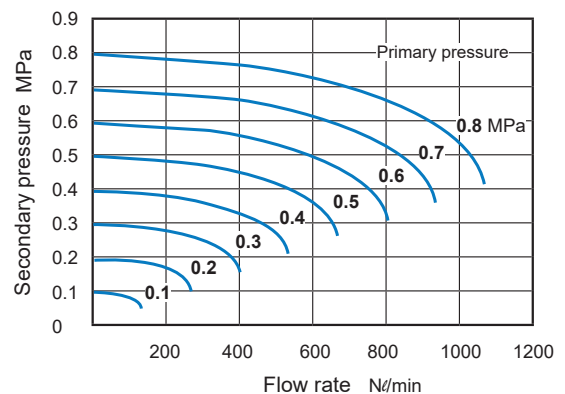

Blocking plate parts

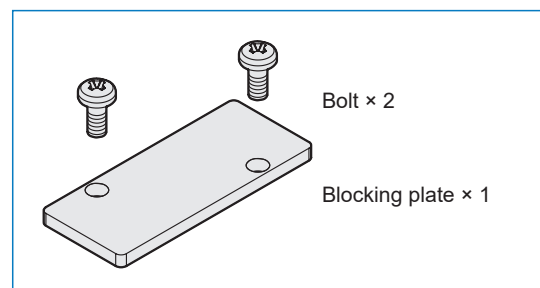

MVAA-180 Dimensions

PILOT VALVE



MVAA-180-4A1

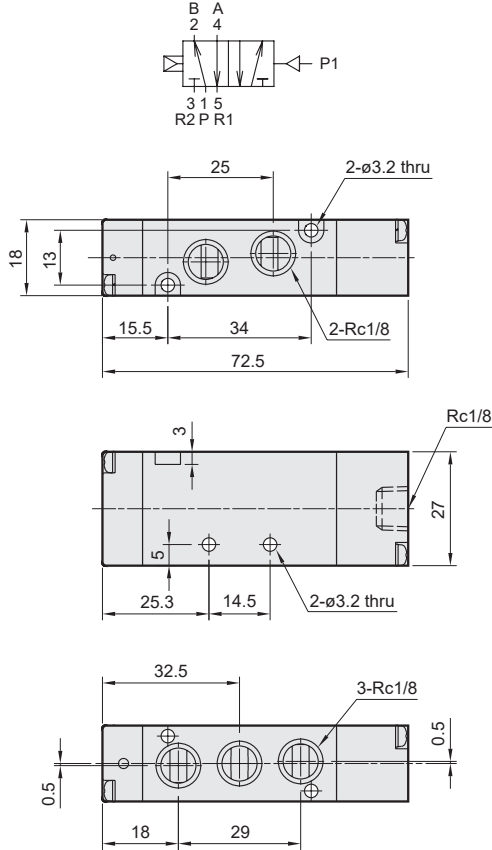

MVAA-180-4A2

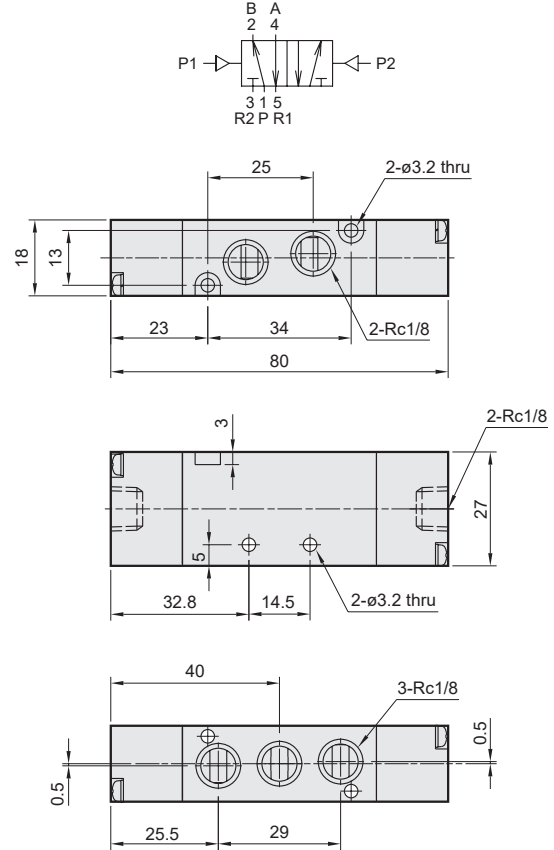

MVAA-180-3A1-NC/NO

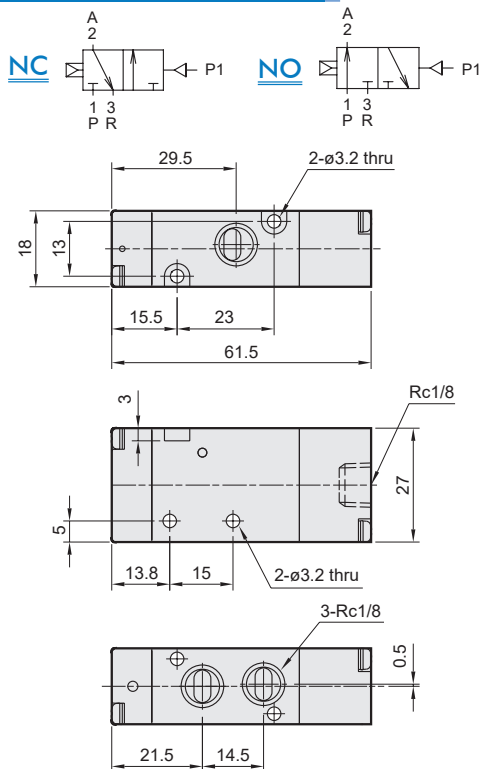

MVAA-180-3A2

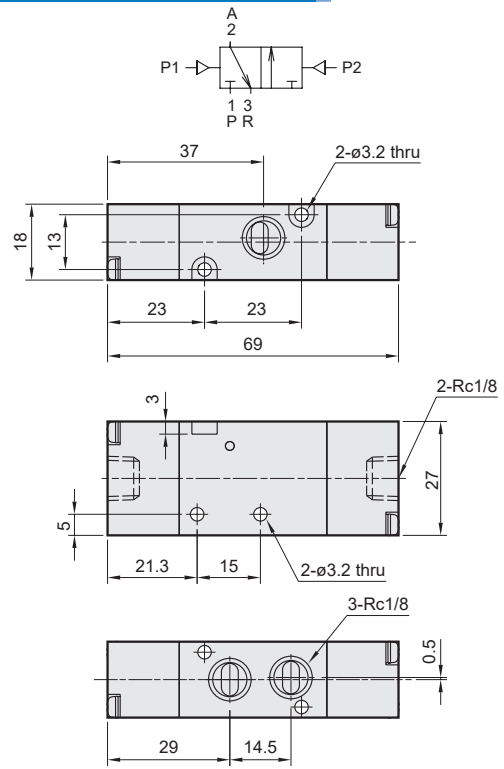

MVAA-180 Manifold

PILOT VALVE



MVSC1-180-5B*

* Use the same manifold with MVSC1.

5 port (for body ported type)

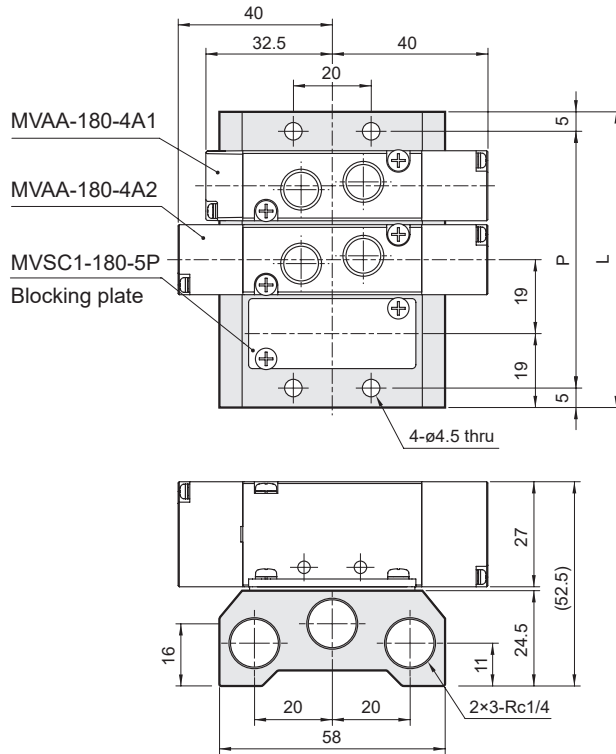

No. of stations	P	L
1	28	38
2	47	57
3	66	76
4	85	95
5	104	114
6	123	133
7	142	152
8	161	171
9	180	190
10	199	209

P: (No. of stations-1)×19+28

L: (No. of stations-1)×19+38

MVSC1-180-3B*

* Use the same manifold with MVSC1.

3 port (for body ported type)

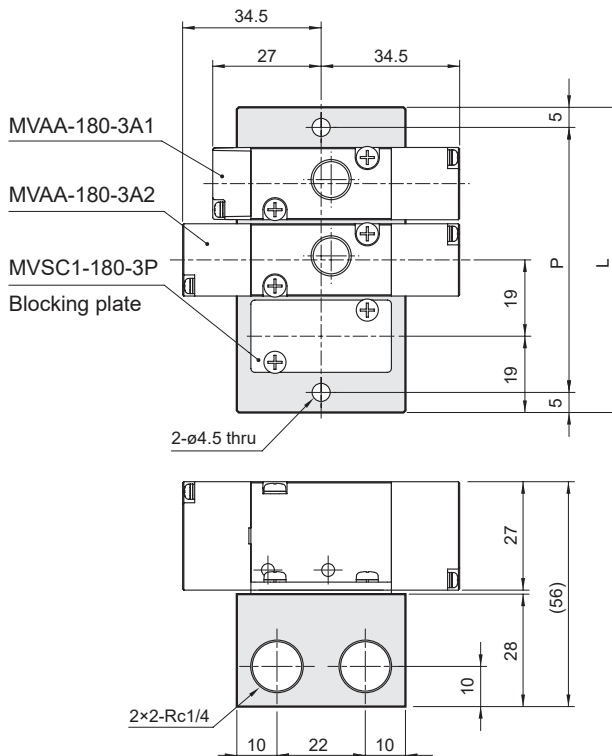

No. of stations	P	L
1	28	38
2	47	57
3	66	76
4	85	95
5	104	114
6	123	133
7	142	152
8	161	171
9	180	190
10	199	209

P: (No. of stations-1)×19+28

L: (No. of stations-1)×19+38

MVAA-220 series

PILOT VALVE



Specification

Model	3A1	3A2	4A1	4A2	4A2C.PR
Bore No.	8A				
Port size	1/4				
No. of port	3		5		
Medium	Air				
Operating pressure range	0~0.8 MPa				
Proof pressure	1 MPa				
Effective orifice	18 mm ²				
Pilot pressure range	(0.3×P*+0.1)~0.8 MPa				
Ambient temperature	-5~+60°C (No freezing)				
Weight	122 g	134 g	106 g	134 g	179 g

* P: Operating pressure.

Order example of valve

MVAA - 220M - 4A2C - NC - G

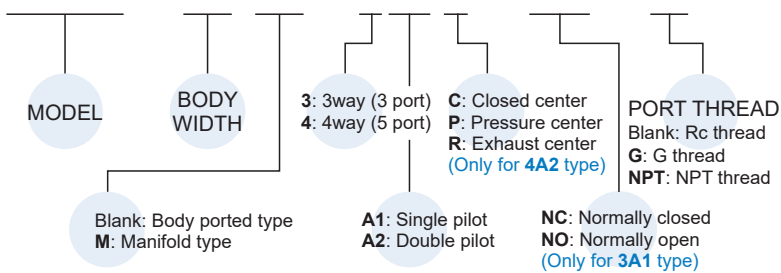

Flow features

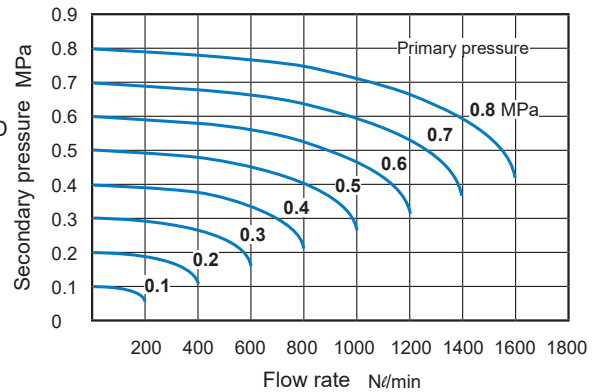

Order example of manifold

MVSC - 220M - 5M3 - G

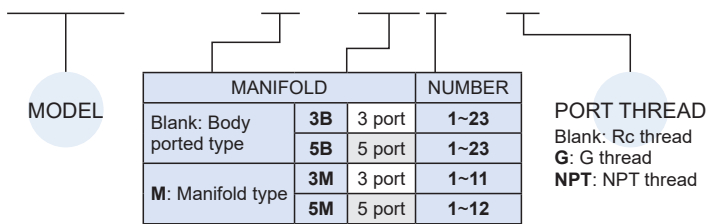

* Use the same manifold with MVSC.
* Starting from 11 stations, manifolds are made to order.

MVAA-220-4A1

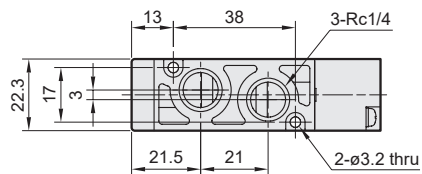

* Use the same blocking plate with MVSC.

Order example of blocking plate

MVSC - 220 - 5P

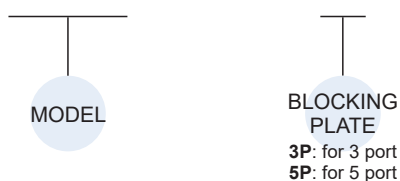

Blocking plate parts

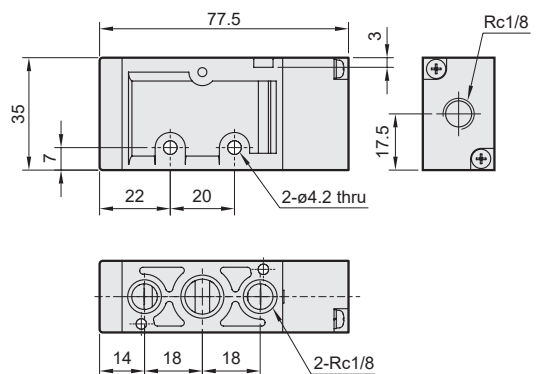
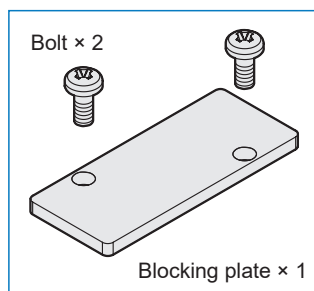

MVAA-220 Dimensions

PILOT VALVE



MVAA-220-4A2

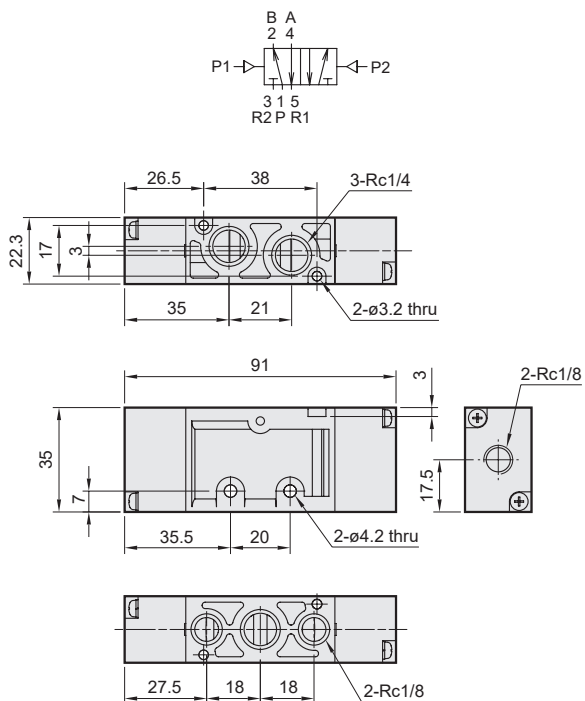

MVAA-220-4A2C.P.R

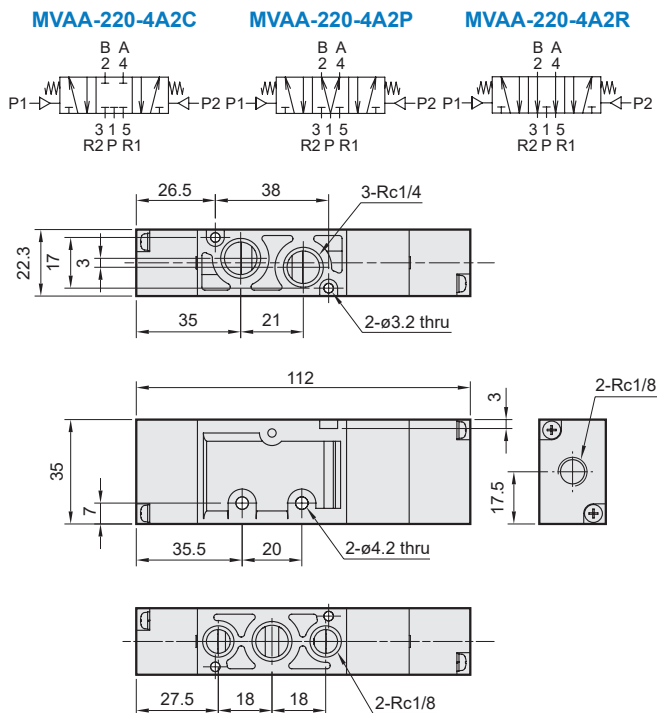

MVAA-220-3A1-NC/NO

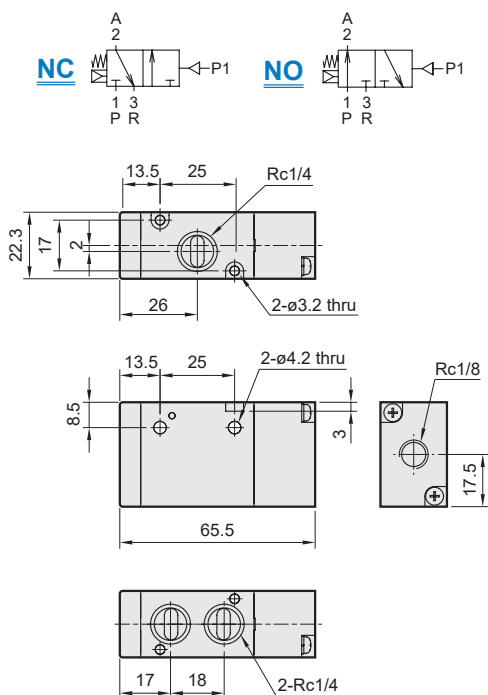

MVAA-220-3A2

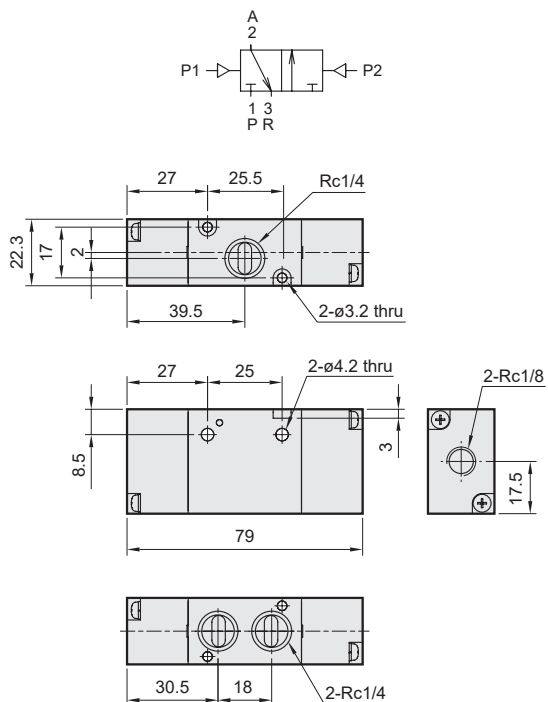

MVAA-220 Manifold

PILOT VALVE



MVSC-220-5B*

* Use the same manifold with MVSC.

5 port (for body ported type)

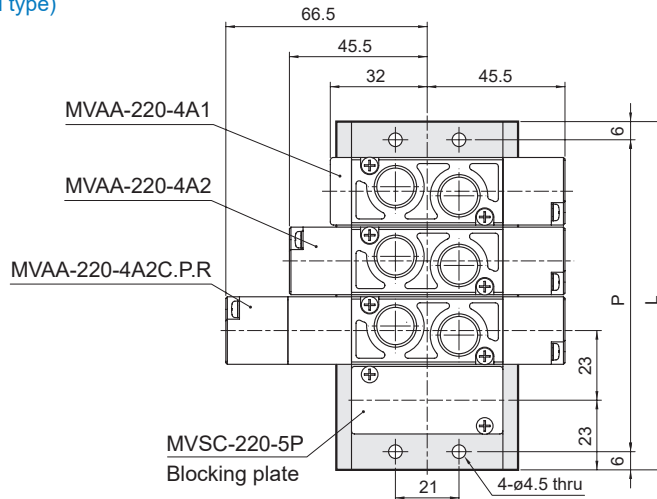

No. of stations	P	L
1	34	46
2	57	69
3	80	92
4	103	115
5	126	138
6	149	161
7	172	184
8	195	207
9	218	230
10	241	253

P: (No. of stations-1)×23+34
L: (No. of stations-1)×23+46

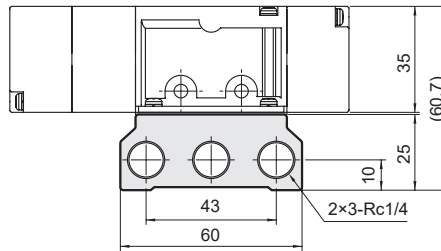

MVSC-220-5M*

* Use the same manifold with MVSC.

5 port (for manifold type)

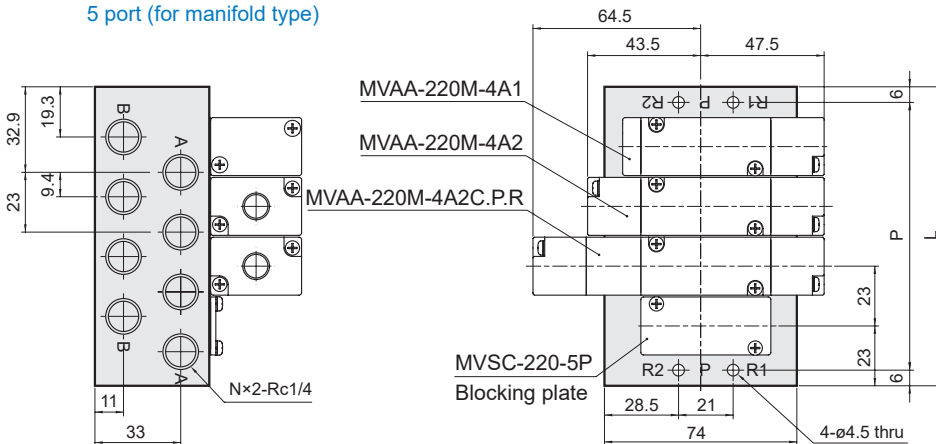

No. of stations (N)	P	L
1	34	46
2	57	69
3	80	92
4	103	115
5	126	138
6	149	161
7	172	184
8	195	207
9	218	230
10	241	253

P: (No. of stations-1)×23+34
L: (No. of stations-1)×23+46

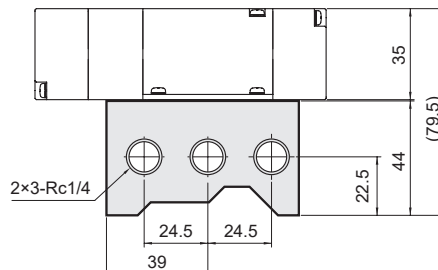

MVAA-220 Manifold

PILOT VALVE



MVSC-220-3B*

* Use the same manifold with MVSC.

3 port (for body ported type)

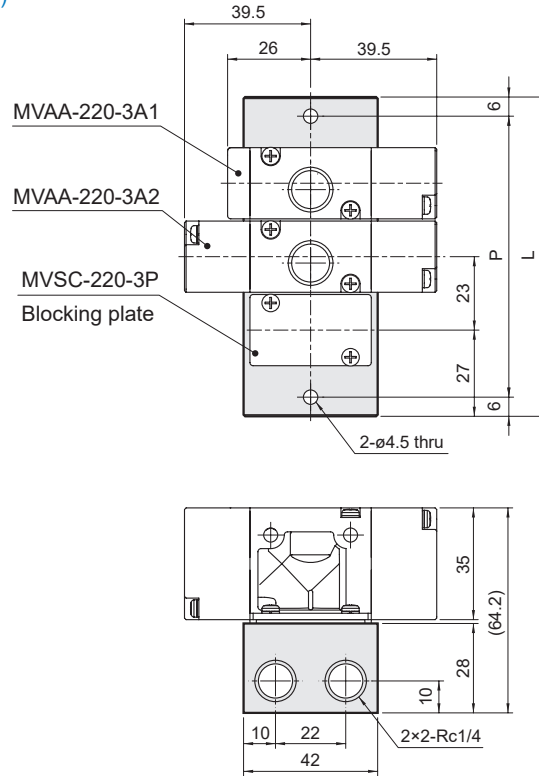

No. of stations	P	L
1	42	54
2	65	77
3	88	100
4	111	123
5	134	146
6	157	169
7	180	192
8	203	215
9	226	238
10	249	261

P: (No.of stations-1)×23+42

L: (No.of stations-1)×23+54

MVSC-220-3M*

* Use the same manifold with MVSC.

3 port (for manifold type)

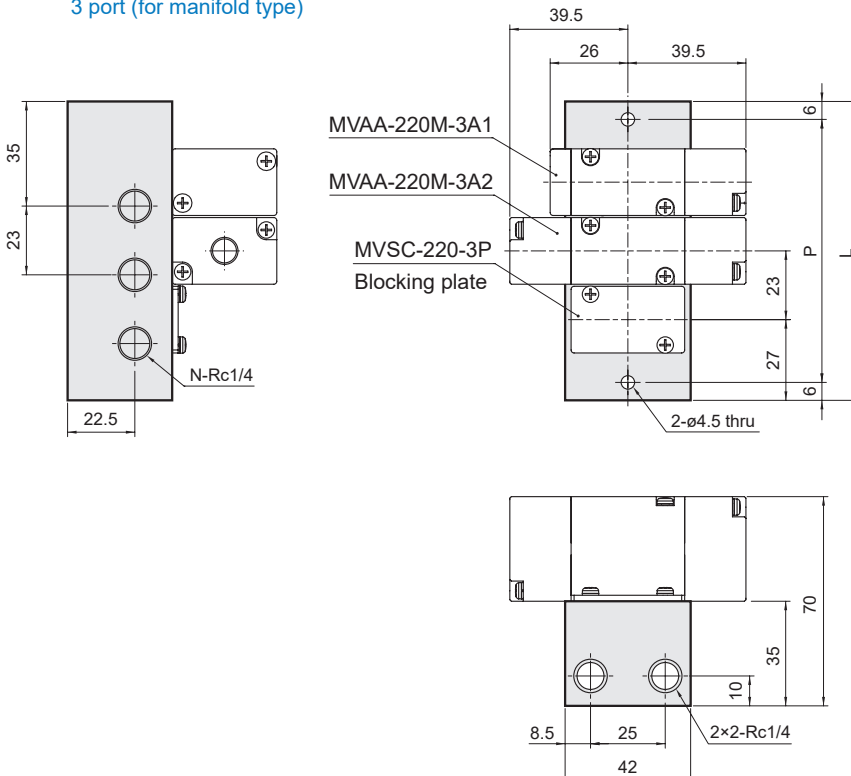

No. of stations (N)	P	L
1	42	54
2	65	77
3	88	100
4	111	123
5	134	146
6	157	169
7	180	192
8	203	215
9	226	238
10	249	261

P: (No.of stations-1)×23+42

L: (No.of stations-1)×23+54

MVAA-460 series

PILOT VALVE

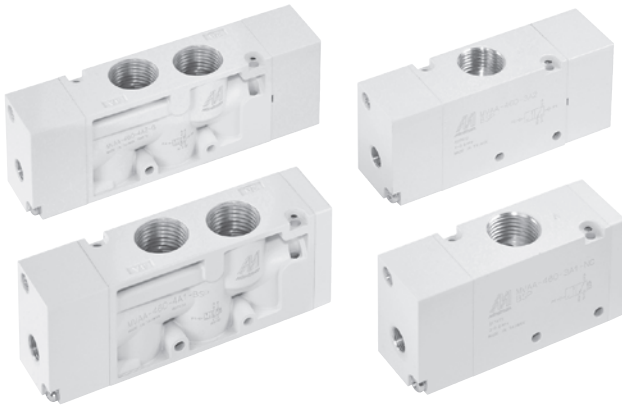

Specification

Model	3A1	3A2	4A1	4A2	4A2C.PR
Bore No.	15A				
Port size	1/2				
No. of port	3		5		
Medium	Air				
Operating pressure range	0~0.8 MPa				
Proof pressure	1 MPa				
Effective orifice	50 mm ²				
Pilot pressure range	(0.34×P*+0.1)~0.8 MPa				
Ambient temperature	-5~+60°C (No freezing)				
Weight	300 g	326 g	275 g	338 g	410 g

* P: Operating pressure.

Order example of valve

MVAA – 460 – 4A2C – NC – NPT

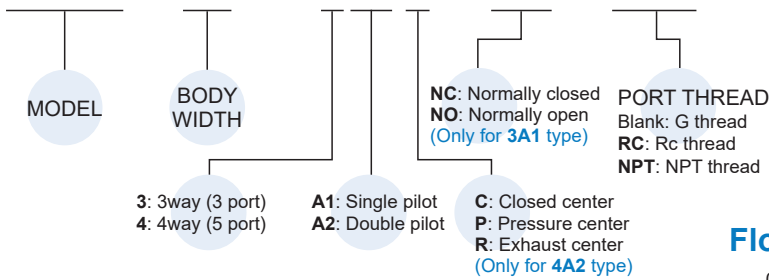

Order example of manifold

MVSC – 460 – 5B3 – NPT

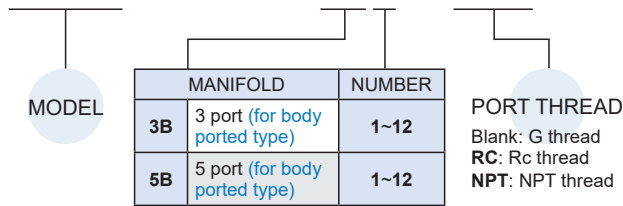

* Use the same manifold with MVSC.

* Starting from 11 stations, manifolds are made to order.

* Use the same blocking plate with MVSC.

Order example of blocking plate

MVSC – 460 – 5P

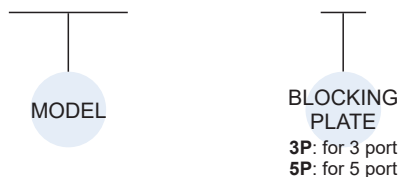

Flow features

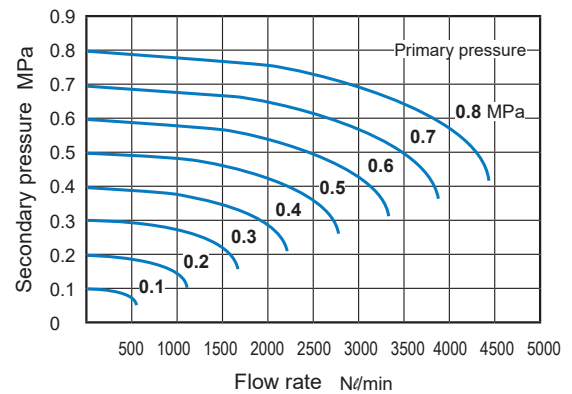

Blocking plate parts

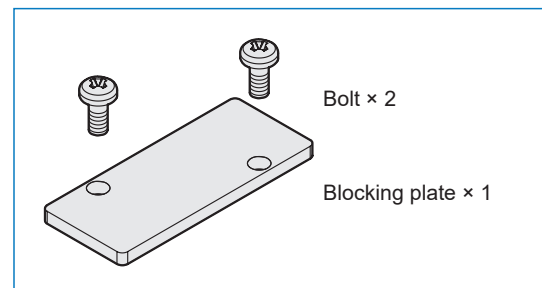

MVAA-460 Dimensions

PILOT VALVE



MVAA-460-4A1

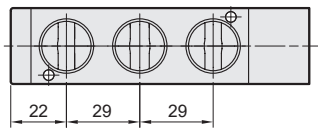
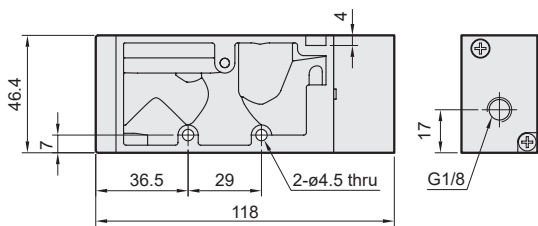
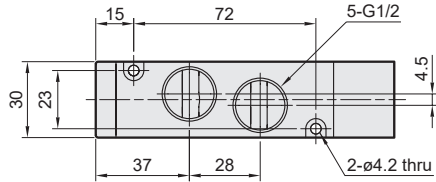
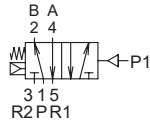

MVAA-460-4A2

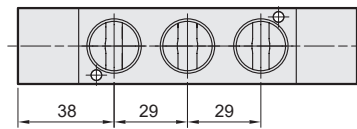
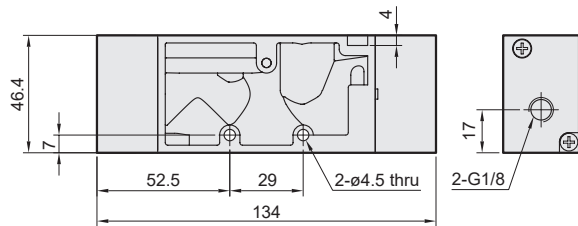
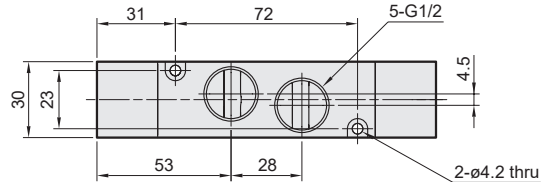
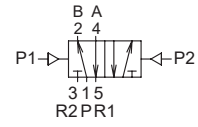

MVAA-460-4A2C.PR

MVAA-460-4A2C

MVAA-460-4A2P

MVAA-460-4A2R

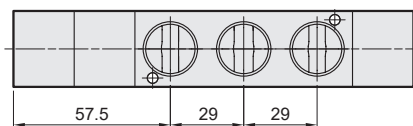
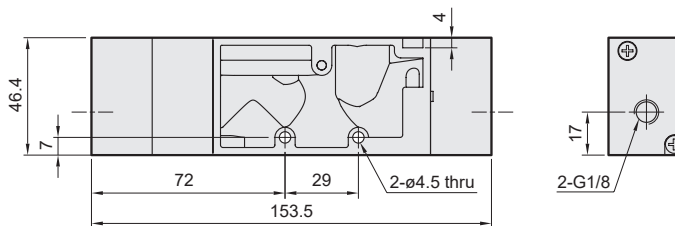
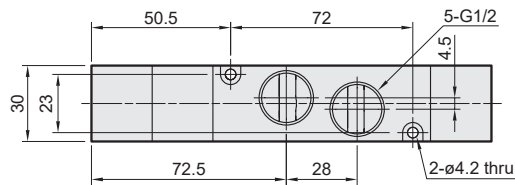
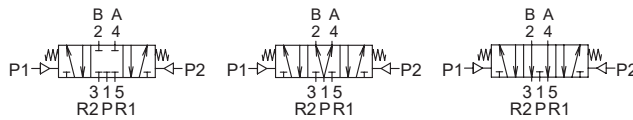

MVAA-460 Dimensions

PILOT VALVE



MVAA-460-3A1-NC/NO

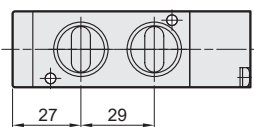
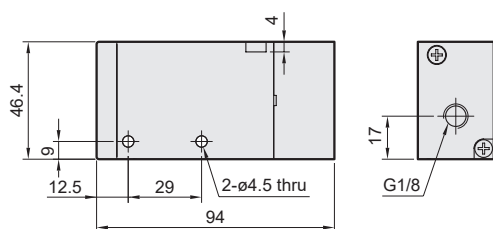
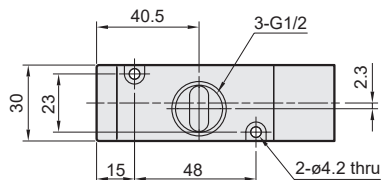
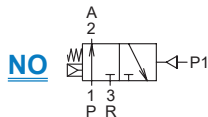
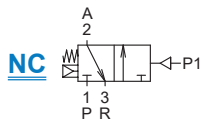

MVAA-460-3A2

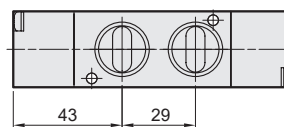
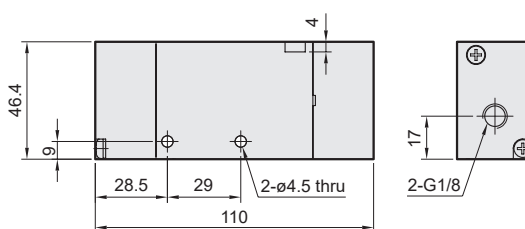
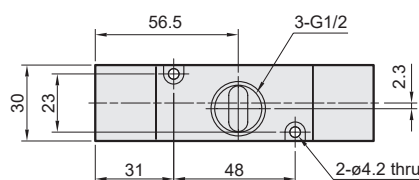
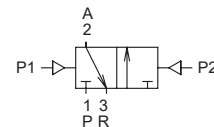

Manifold of pilot valve

MVSC-460-3B*

* Use the same manifold with MVSC.

3 port (for body ported type)

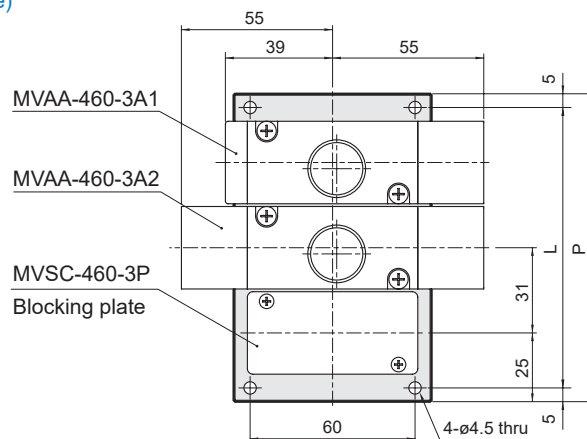

No. of stations	P	L
1	40	50
2	71	81
3	102	112
4	133	143
5	164	174
6	195	205
7	226	236
8	257	267
9	288	298
10	319	329

P: (No. of stations-1)×31+40

L: (No. of stations-1)×31+50

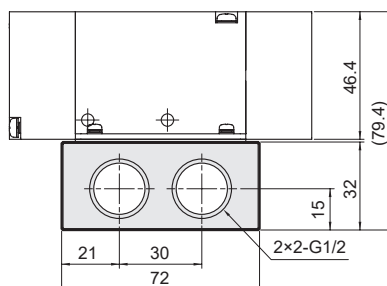

MVAA-460 Manifold

PILOT VALVE



MVSC-460-5B*

* Use the same manifold with MVSC.

5 port (for body ported type)

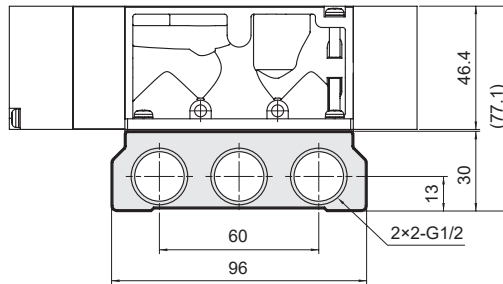
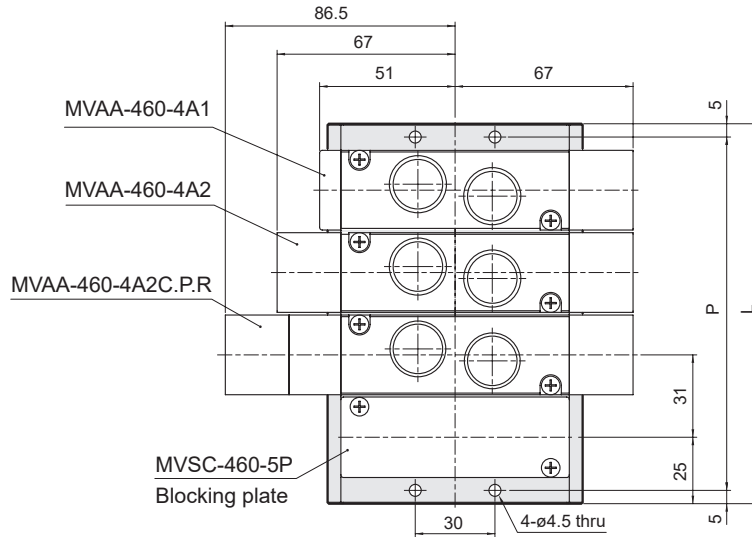

No. of stations	P	L
1	40	50
2	71	81
3	102	112
4	133	143
5	164	174
6	195	205
7	226	236
8	257	267
9	288	298
10	319	329

P: (No. of stations-1)×31+40

L: (No. of stations-1)×31+50