

MVSC-220 series

SOLENOID VALVE

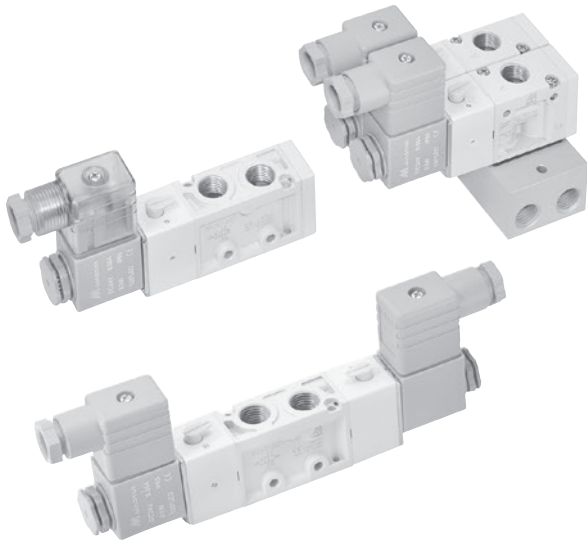

mindman



Specification

Model	3E1	3E2	4E1	4E2	4E2 C.P.R
Bore No.	8A		6A, 8A		
Port size	1/4		1/8, 1/4		
No. of port	3		5		
No. of position	2		2	3	
Medium	Air				
Operating pressure range	0.2~0.8 MPa			0.3~0.8 MPa	
Operating pressure (LP)	0~0.8 MPa				
Pilot pressure range (LP)	(0.34×P*+0.1)~0.5 MPa				
Proof pressure	1 MPa				
Effective orifice	18 mm ²			16 mm ²	
Response time	30 ms			40 ms	
Ambient temperature	-5~+50°C (No freezing)				
Voltage	AC110V, 220V, 24V (50/60)Hz, DC24V, 12V				
Power consumption	AC=4.8/4.4VA, 6/4.9VA, 6.7/5.4VA, DC=2W, 2.5W				
Available voltage range	±10%				
Insulation class	F class				
Weight	181 g	294 g	198 g	313 g	352 g

* P: Operating pressure

Order example of valve

MVSC – 220M – 4E2C – NC – □ – AC110 – L – LP – G

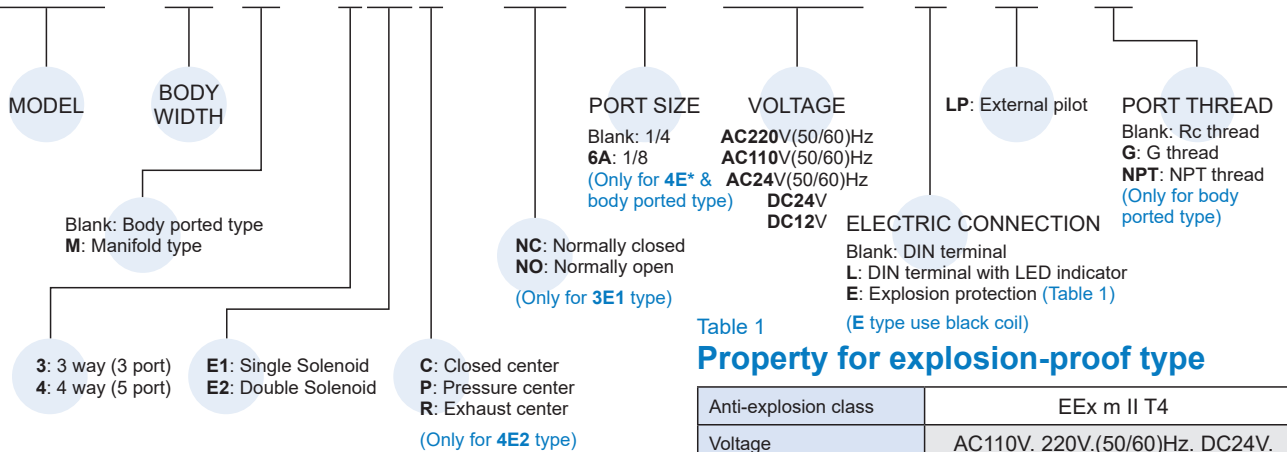

Table 1

Property for explosion-proof type

Anti-explosion class	EEx m II T4
Voltage	AC110V, 220V, (50/60)Hz, DC24V.
Power consumption	AC=4.4VA DC=5W
Available voltage range	±10%
Insulation class	F class
Wire length	3 m

Order example of manifold

MVSC – 220M – 5M3 – G

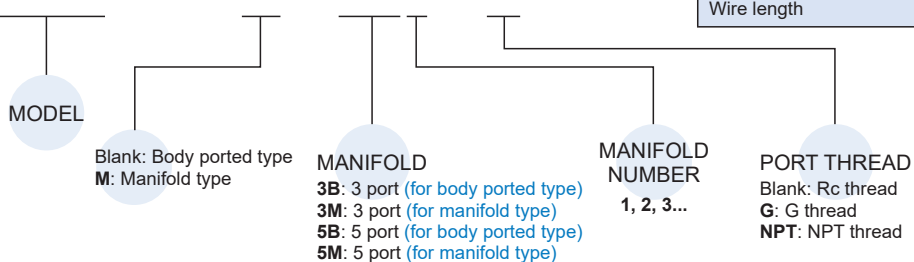

MVSC-220 Dimensions

SOLENOID VALVE



MVSC-220-4E1

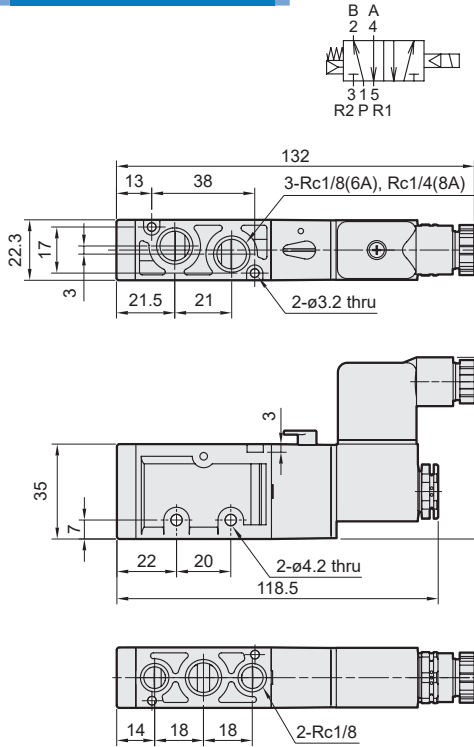

MVSC-220-4E2

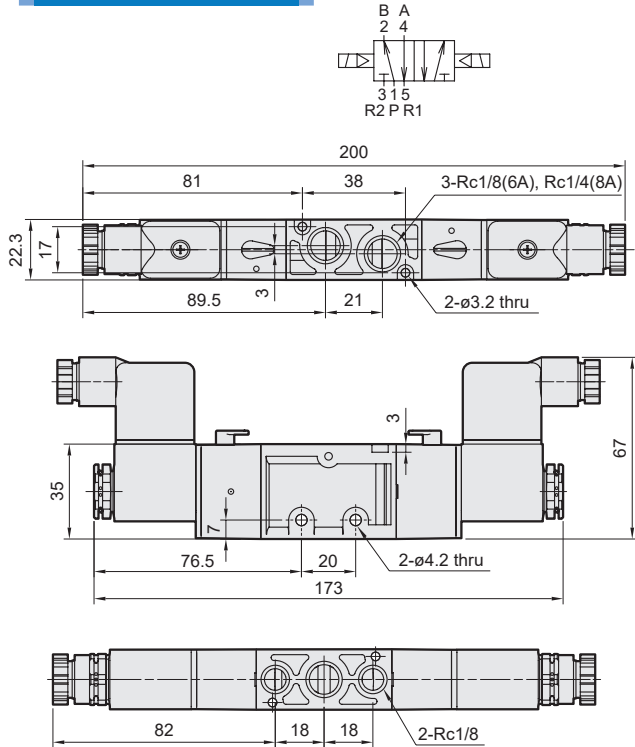

MVSC-220-4E2C.PR

MVSC-220-4E2C MVSC-220-4E2P MVSC-220-4E2R

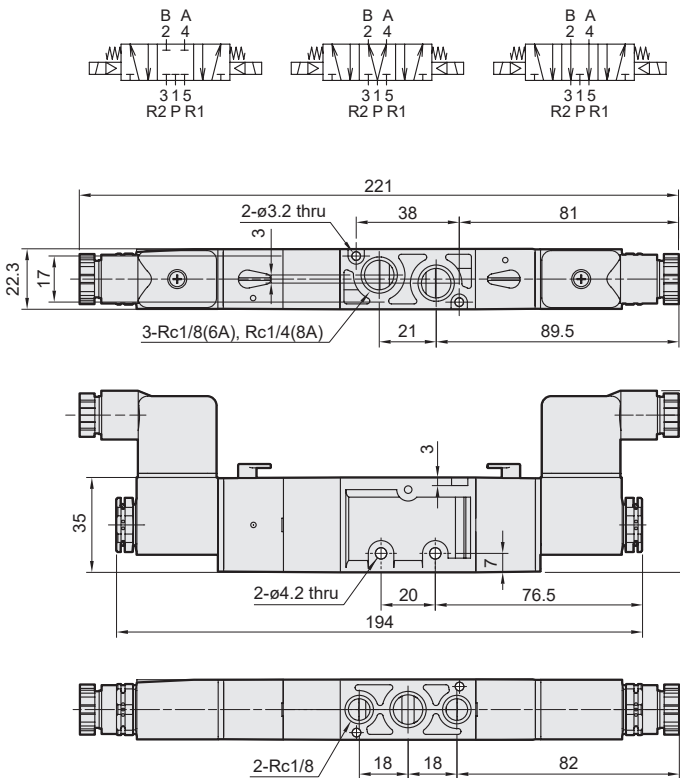

LP

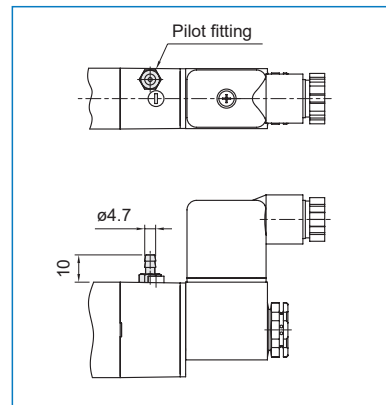

Flow features

MVSC-220-3E1/3E2/4E1/4E2

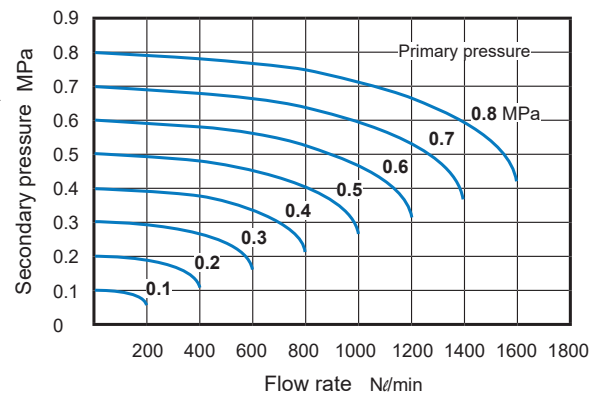

MVSC-220 Dimensions

SOLENOID VALVE



MVSC-220-3E1-NC/NO

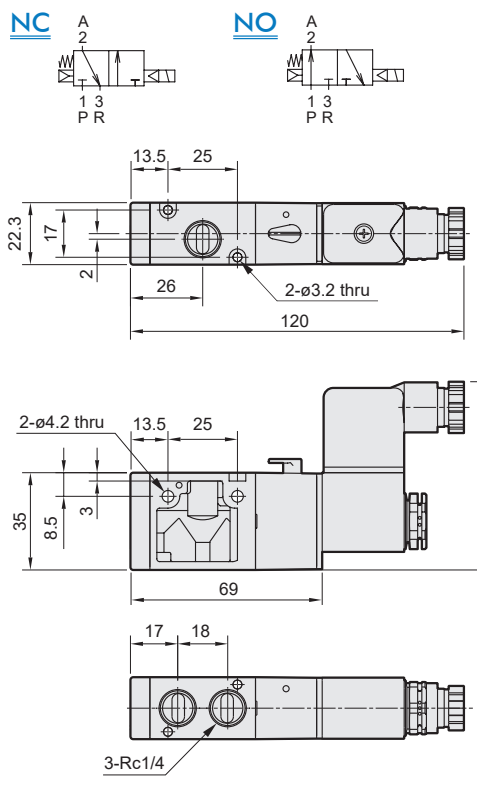

MVSC-220-3E2

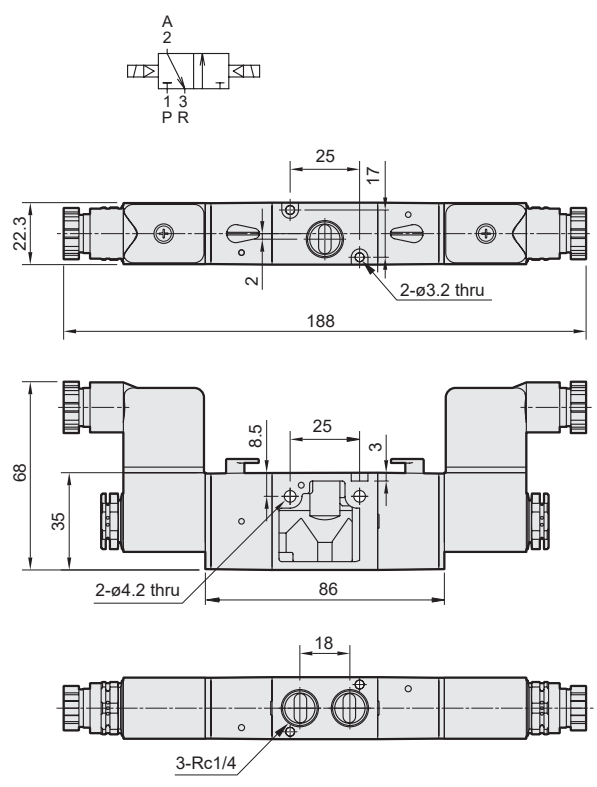

Manifold of solenoid valve

MVSC-220-3B*

3 port (for body ported type)

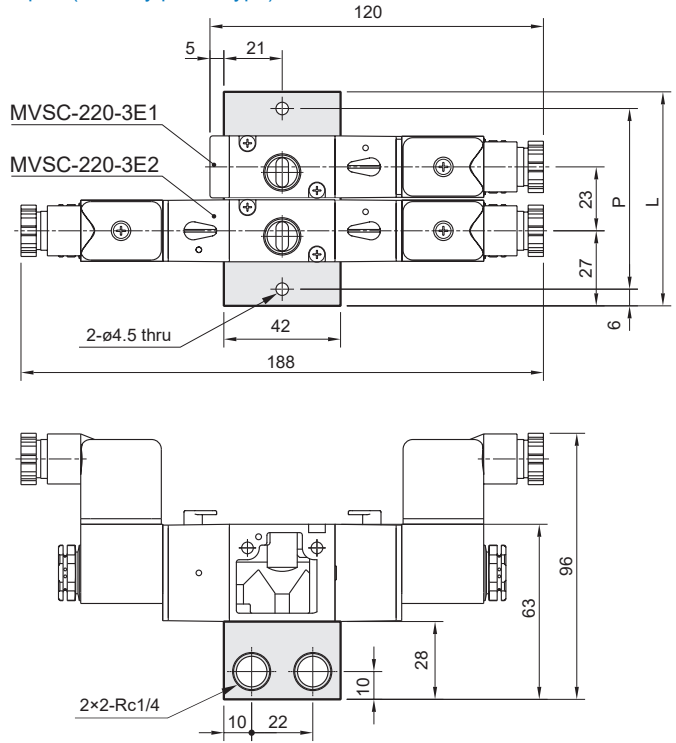

No. of stations	P	L
2	65	77
3	88	100
4	111	123
5	134	146
6	157	169
7	180	192
8	203	215
9	226	238
10	249	261

MVSC-220 Manifold

SOLENOID VALVE



MVSC-220M-3M*

3 port (for manifold type)

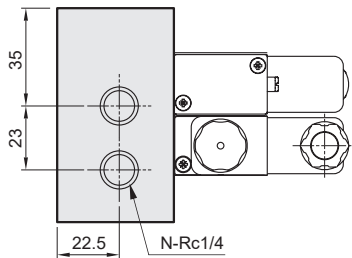

No. of stations (N)	P	L
2	65	77
3	88	100
4	111	123
5	134	146
6	157	169
7	180	192
8	203	215
9	226	238
10	249	261

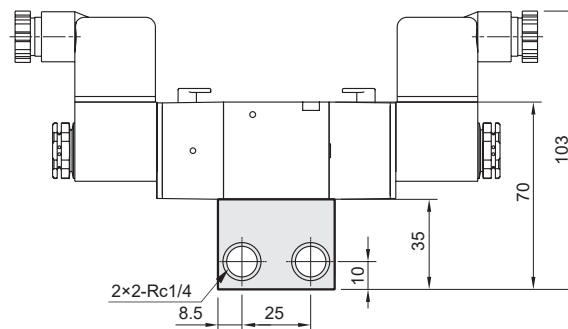
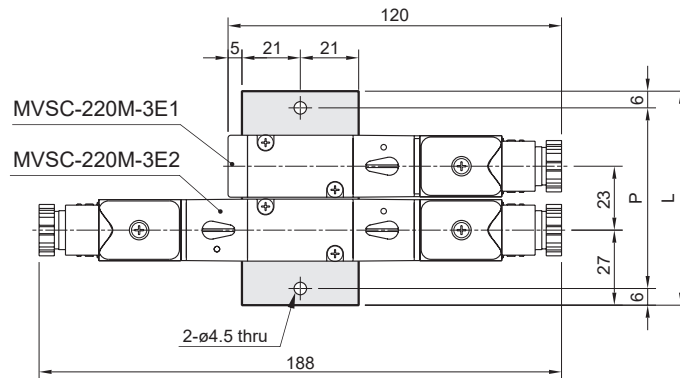

MVSC-220-5B*

5 port (for body ported type)

No. of stations	P	L
2	57	69
3	80	92
4	103	115
5	126	138
6	149	161
7	172	184
8	195	207
9	218	230
10	241	253

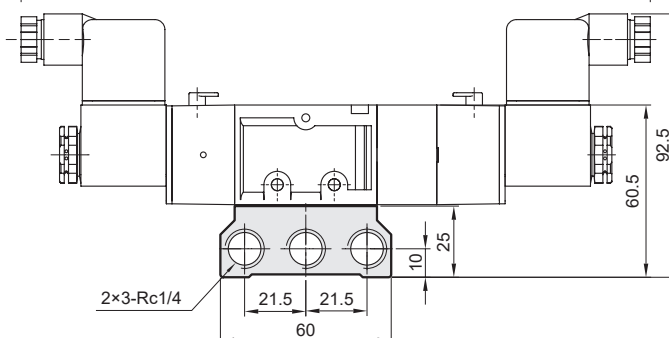
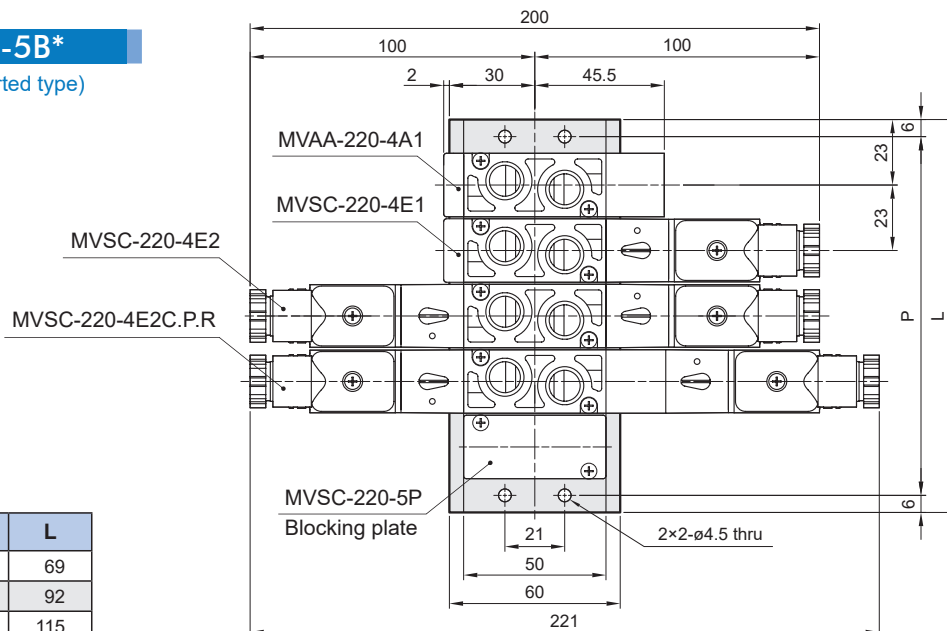

MVSC-220 Manifold

SOLENOID VALVE



MVSC-220M-5M*

5 port (for manifold type)

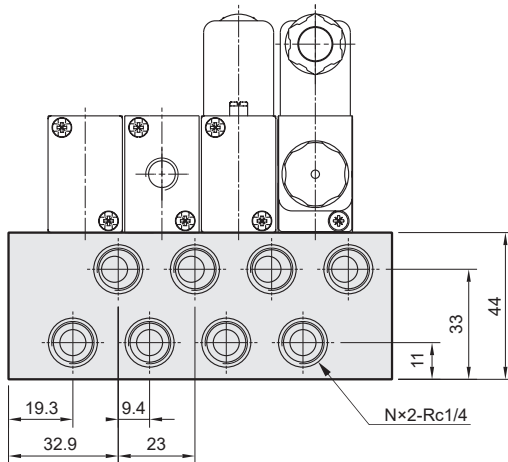
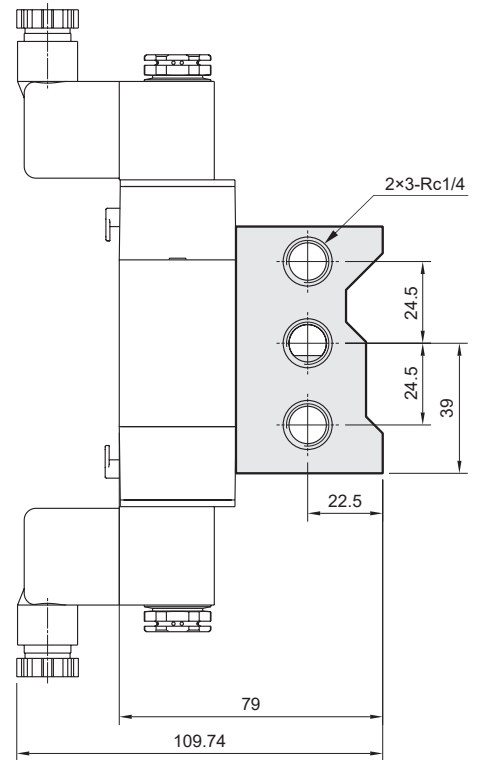
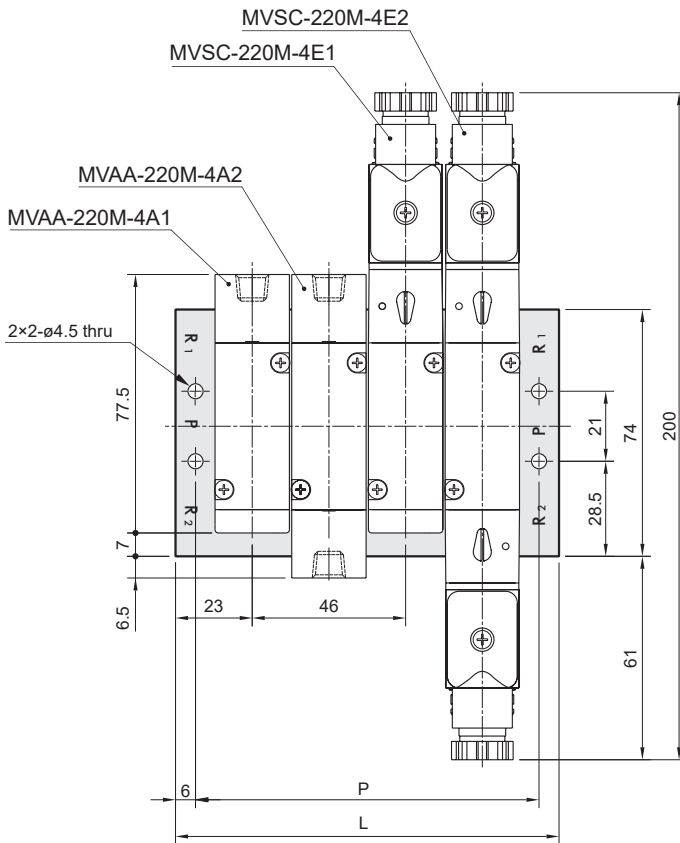

No. of stations (N)	P	L
2	57	69
3	80	92
4	103	115
5	126	138
6	149	161
7	172	184
8	195	207
9	218	230
10	241	253